

KRONES Capping technology

Capper models for a wide range of applications



Good, reliable sealing

Beverage containers are used in various sizes and shapes worldwide and there is accordingly great diversity in container closures. Cappers from Krones can be used to apply all common closure types on containers, from plastic screw caps and aluminium roll-on caps through crown necks, twist-off and ring-pull closures to natural corks. And if you are using a closure that is not included in the standard programme of KRONES cappers, we can provide you with a special capper model that exactly meets your requirements.

Capper type	Neck handling	Base handling
Modulcap CM	X	X
Modulcap CS	X	
Crowners		X
Aluminium roll-on capper		X
Natural cork capper		X



KRONES Modulcap CM

The mechanical screw capper

KRONES Capping technology

The market offers many different designs of plastic screw caps for glass and PET bottles. The KRONES Modulcap CM screw capper is suitable for many of these closure types and can screw the closures onto the bottles with precision, even at high speeds. A hysteresis clutch ensures that the screw caps are applied at a constant torque, regardless of the machine output. The Modulcap CM also meets high standards of hygiene as the sealing heads are easy to clean thanks to their open construction.



*Modulcap CM with
non-returnable PET containers*

KRONES Modulcap CM

Figures, data and facts

KRONES Capping technology

Method of operation

The screw caps are spaced and oriented in the sorter, and then fed to the sealer from above. A holding device positively clamps the caps in the capping head. Glass bottles are prevented from turning by a tension belt and centre starwheel; PET bottles are held in place on the neck starwheel disk by spikes.

The capping head applies the closure to the bottle. The closure is pressed onto the bottle by means of spring pressure. Simultaneously, it is screwed to the thread of the bottle neck finish. As soon as the rotation is ended and the required tightening torque is applied to the cap, a hysteresis clutch ends the capping process. This clutch allows for smooth braking and a constant tightening torque at all filling speeds.

Application

With the respective handling parts, the Modulcap CM processes the following single-threaded or multi-threaded cap types:

- 26-mm caps
- 28-mm caps
- 38-mm caps
- Sports caps with diameters of 28 mm and 38 mm
- 30/25-mm caps

Output range

Depending on the type of closure, the Modulcap CM can apply screw caps on between 10,000 and 72,000 bottles per hour.

Type designation

- C** Chucks (cap retainers)
- M** Mechanical

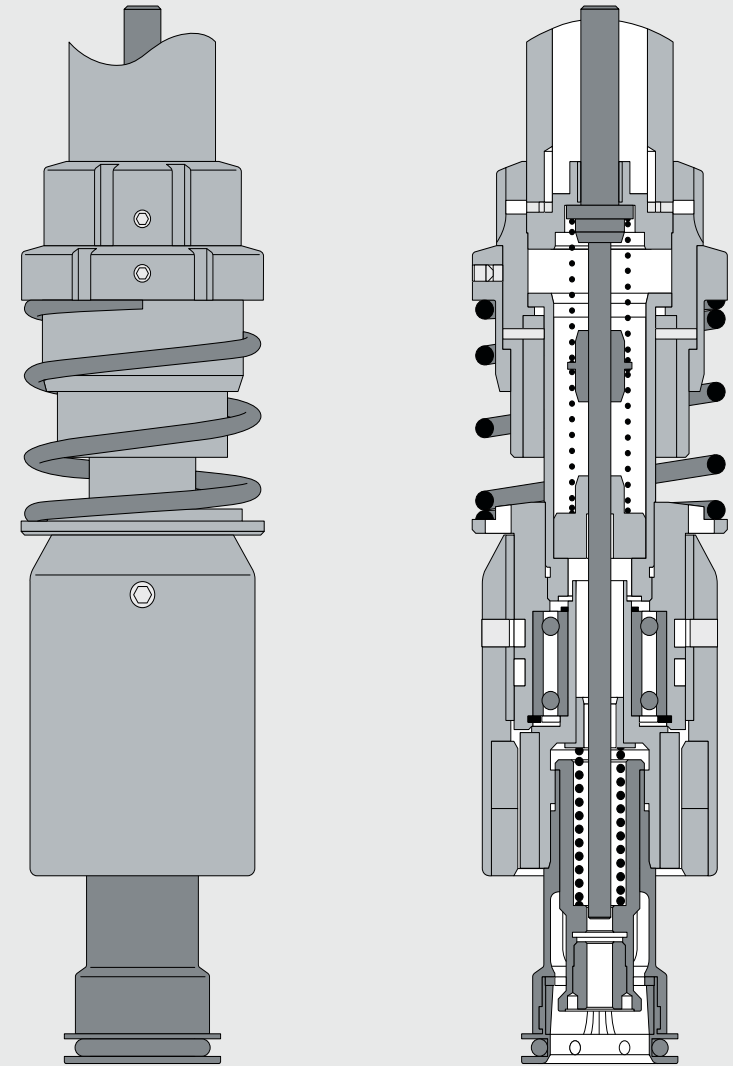

Cross-section of the capping head on the Modulcap CM screw capper

KRONES Modulcap CM

Figures, data and facts

KRONES Capping technology

Design features

- All main parts made of stainless steel Wst. AISI 304
- Pick station with adjustable height
- Torque and spring force of the capping head are adjustable
- Flushable capping cone
- Replaceable capping cone inserts
- Exchangeable spikes in the bottle support rings for PET bottles
- Height of the top part of capper can be adjusted by motor with bottle selection feature

- Double sorter with distribution gate (for blow moulding machine-filler blocks)

Your benefits

- **Caps are fitted perfectly**
Use of a hysteresis clutch ensures screw caps are applied at a constant force.
- **Optimum cleaning options**
The capping heads can be cleaned perfectly with hot water or foam.

Additional equipment

- Gripper head for special closures
- Separate capping head drive for multi-threaded caps
- Separate capping head drive for the same rotational speed at different machine output levels
- Screw thread spraying and steaming
- Cap spraying and steaming
- Flushing equipment
- UV lamp for cap disinfection
- Dust blow-off with ionised air and suction
- Closure immersion bath
- KRONES Capcade cascade sorter

Machine pitch	87	94	103	113	126	141	188	226	283
Pitch circle diameter (mm)									
360	13	12	11	10	9	8	6	5	4
540		18		15		12	9		
720	26	24	22	20	18	16	12	10	
1,080	39	36	33	30	27	24	18	15	



*Cascade sorting system
for caps*

KRONES Modulcap CS

Aseptic screw capper

KRONES Capping technology

In the KRONES Modulcap CS screw capper, only the cap retainer and rejection device are located above the bottle neck finish. Thanks to a reduction in the number of machine components which are absolutely necessary in this area, the microbiological basic conditions, and thus the aseptic capping process, can be optimised. The lifting cam for controlling the capping heads is arranged underneath the open bottle. In addition, the servomotors for driving the capping heads have been shifted inwards and thus moved away from the bottle neck finish. In the Modulcap CS, the servomotor does not complete the lifting movement. The vertical movement is performed solely by the capping head.



*Control cam below
the bottle neck finish*

KRONES Modulcap CS

Figures, data, facts

KRONES Capping technology

Method of operation

After the caps are separated, they are picked up by the capping head at the pick-up station. Using an antitorsion device underneath the neck ring, the plastic bottles are secured against rotation while the cap is applied. The capping head fixes the cap in place and presses it onto the bottle with a predefined stroke. The servomotor transferring the power through gear rims and onto the capping head starts the application.

Drive technology with servomotor

- Saving of data tracking and monitoring of screw-on values with continuous documentation within the servocontroller
- Optimum positioning of multi-threaded caps with fixed capping head
- Quick and hygienically-safe adjustment of the tightening torque without accessing the machine for cap change-over
- Achievement of different capping-head rotational speeds at different cap thread slants

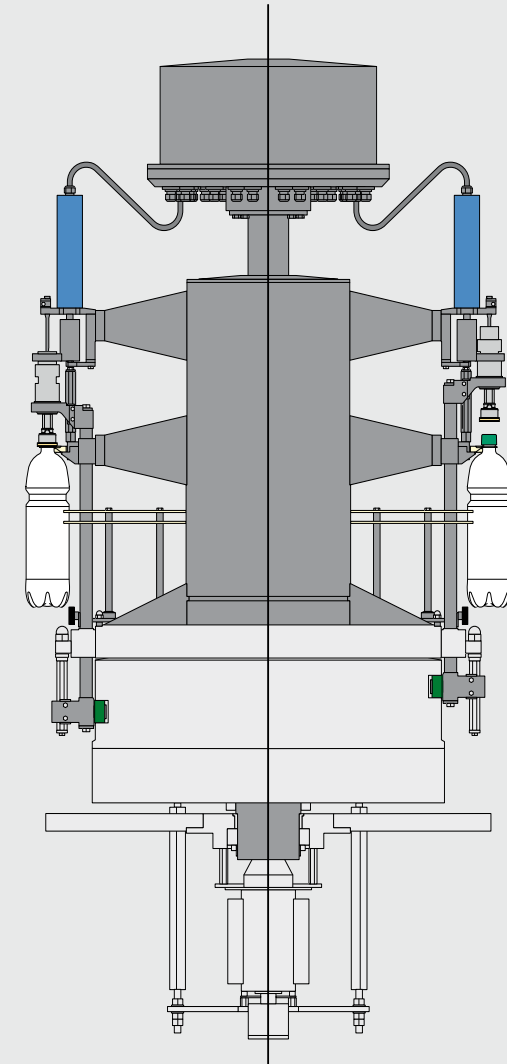

*Cross-section of a
Modulcap CS
screw capper*

KRONES Modulcap CS

Figures, data, facts

KRONES Capping technology

Application

With the respective handling parts, the Modulcap CS processes the following single-threaded or multi-threaded cap types:

- 26-mm caps
- 28-mm caps
- 38-mm caps
- 28-mm and 38-mm sports caps
- 30/25-mm caps

Output range

Depending on the type of cap used, the Modulcap CS can apply screw caps to between 10,000 and 60,000 containers per hour.

Type designation

- C Chucks (cap retainers)
- S Servomotor, installed inside

Design features

- The machine is constructed using a selection of stainless steels which have been optimised for the application in hand
- Complete cleaning and sterilisation possible
- Pick-up station on a column in hygienic design
- Ceramic machine bearings

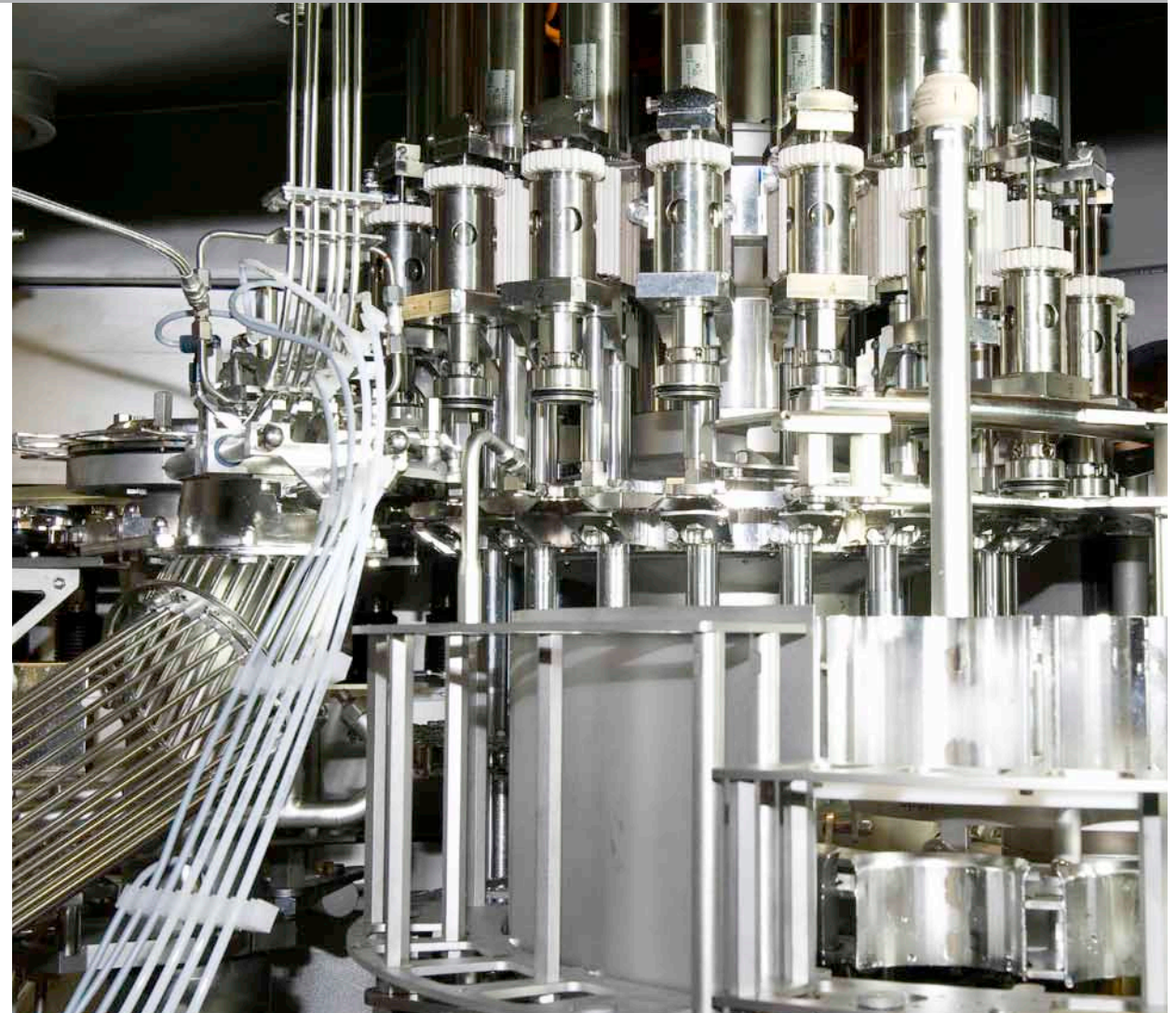

Cap feed chute with emptying device for cap change-over

KRONES Modulcap CS Additional equipment

KRONES Capping technology

- CapAsept D: Cap disinfection by dry sterilisation with hydrogen peroxide
- CapAsept L: Cap disinfection by wet sterilisation in an immersion tank

*CapAsept D –
dry cap sterilisation
with hydrogen peroxide*

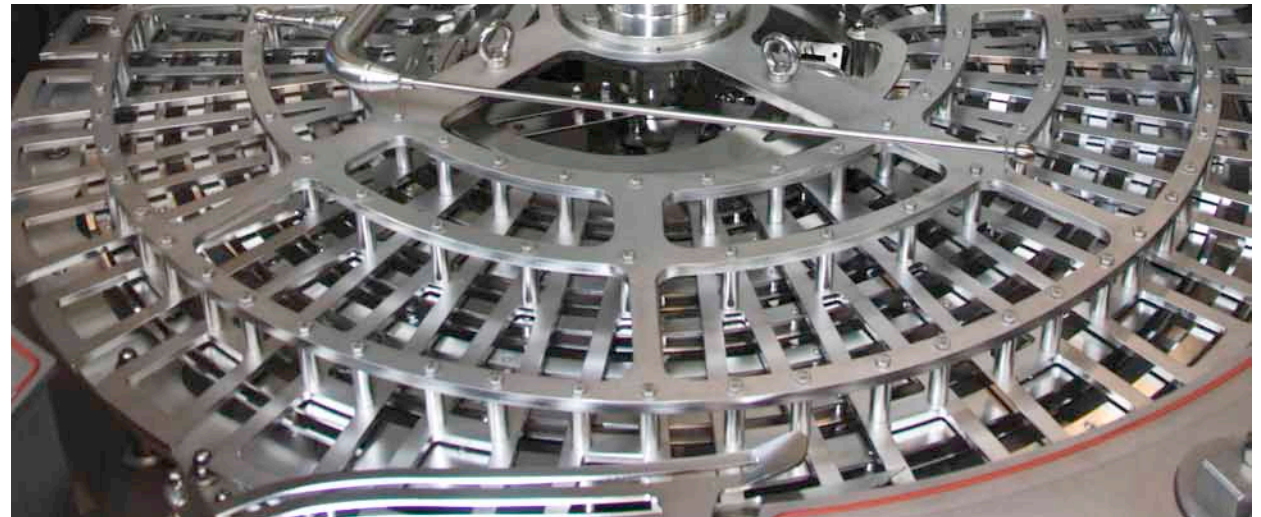

*CapAsept L –
cap sterilisation in a
peracetic-acid immersion tank*

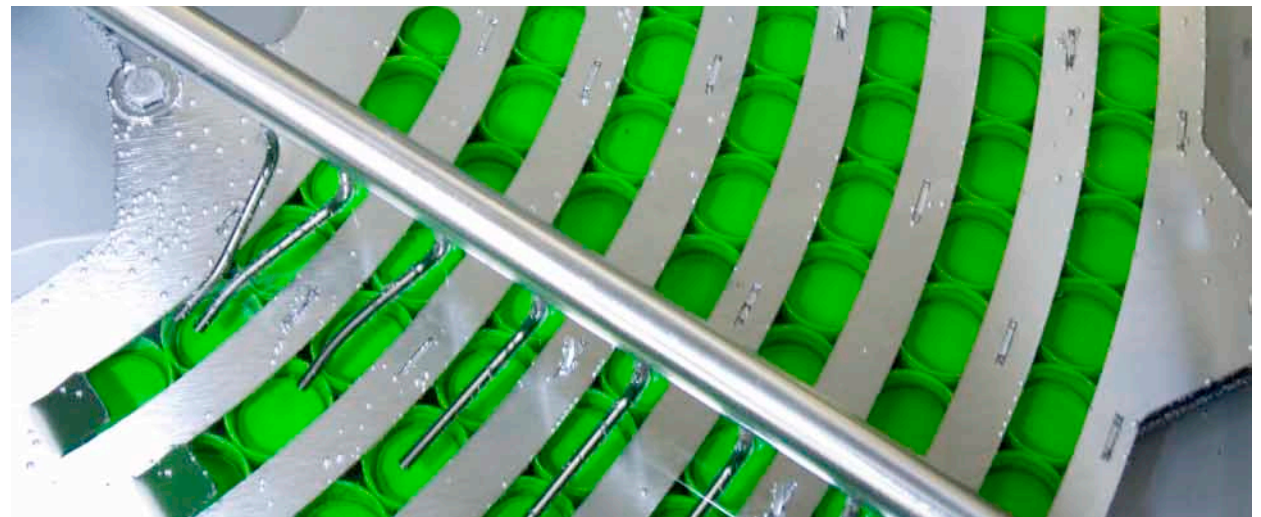

KRONES Modulcap CS

Your benefits

KRONES Capping technology

- **Hygienically optimised design**
The drives are positioned so that the spreading of germs to the still-open bottle is avoided.
- **Perfect cap position**
The servocontroller for the capping process precisely monitors the moment of application. This means that the screw caps are applied with a consistent force.
- **Safe cap feed**
The sterilised caps are fed hygienically to the pick-up station.
- **Optimum cleaning**
The machine can be cleaned very effectively using foam and spray disinfection methods. Thanks to the open design of the pick-up station and the cap retainer, each individual component can be easily reached.
- **Easy maintenance**
All component groups in lubrication-free and maintenance-free design.



KRONES Crowners

KRONES Capping technology

The KRONES Crowner features masterful precision in glass bottle capping. The crowns are conveyed through a flat crown feeder into a guide chute, thus ensuring very gentle treatment. In the microbiologically-improved chute they are steered to the crown transfer unit. The patented crown transfer unit positioned within the machine offers a high degree of reliability and capping precision. In addition, the open design of the crowning head allows it to be optimally cleaned, thus guaranteeing a high standard of hygiene.



KRONES Crowners

Figures, data and facts

KRONES Capping technology

Method of operation

Once the crown has been fed from the crown chute into the transfer segment, a magnet is used for the further guidance of the crown. A pushing notch is then used to position the crown on the ejection plunger of the capping head. The crowning head is lowered until the crown in the crowning throat is placed on the bottle. The bottle then holds it in place. Afterward only the crowning throat continues to be lowered. In the first phase, only the force of the guiding springs has any effect on the crown.

In the second crowning phase, the ejection spring is pressed and the bottle is subjected to an increased amount of pressure. The crowning procedure is completed once the crown has been introduced 7.7 mm into the crowning throat. In doing so, the crown is located 1 mm inside the cylindrical area of the crowning throat and the required crown diameter of between 28.6 and 28.7 mm has been exactly obtained. This completes the crowning procedure. The crowning force once again drops. The delayed activity of the ejection spring guarantees high crowning quality while applying a low level of pressure on the bottle. The plunger

is then blocked while the crowning throat is further lowered over the crown. At this time, the bottle height is also compensated. A bottle which is too tall presses the bottle plate downwards until the lowest area of the crowning head has been reached. Controlled by the lifting cam, the crowning head is raised again and the guiding spring pushes the ejection plunger back to its initial position.

Application

Capping of glass and PET bottles with crowns, twist-off and ring-pull closures

Output range

The Crowner can fit crowns on between 10,000 and 78,000 bottles per hour.

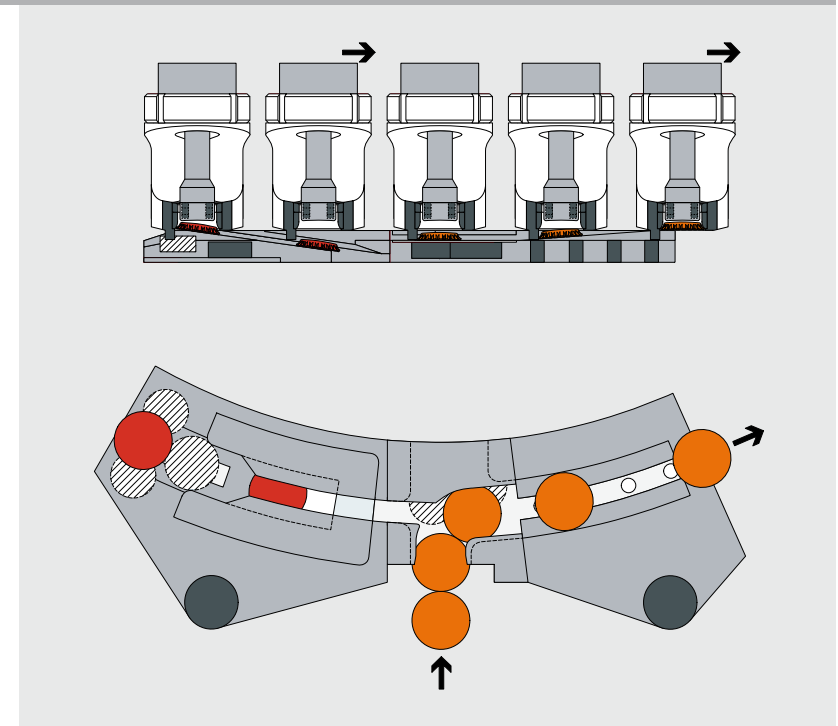

Crown scraping and feed

KRONES Crowners

Figures, data and facts

Design features

- All main parts made of stainless steel Wst. AISI 304
- Flushing of cap transfer unit and capping head
- Motorised height adjustment of the crowner top part with bottle selection feature

Additional equipment

- UV lamp for cap disinfection
- Dust blow-off with ionised air and suction
- Additional flushing equipment

Your benefits

- **Precision**
Crowns enter the line with a defined alignment and are precisely positioned on the transfer plate by a draw-in magnet.
- **Designed for practical applications**
A bottle-neck centring system ensures that even bottles with inaccurate dimensions are reliably sealed.
- **Can be optimally cleaned**
The capping heads can be cleaned perfectly with hot water or foam.

Machine pitch	87	94	103	113	126	141	188	226	283
Pitch circle diameter (mm)									
360	13	12	11	10	9	8	6	5	4
540		18		15		12	9		
720	26	24	22	20	18	16	12	10	
1,080	39	36	33	30	27	24	18	15	



Crowner on the Sensometric VPVI filler

KRONES Roll-on unit for aluminium caps

KRONES Capping technology

Closure of aluminium roll-on caps is a standard procedure in many areas of beverage bottling. The design of the aluminium roll-on capper implements the latest knowledge from capping technology and hygiene: The machine is made entirely of stainless steel and works with grease-free lift cylinders and roll-on capping heads and therefore ensures excellent options for cleaning and disinfection. Moreover, utmost attention was paid to a low-maintenance design of the bearing points and guides, which provides great advantages during day-to-day machine operation.



The removed capping head, a thread roller arm and the plunger



Aluminium roll-on capper with supply chute

KRONES Roll-on unit for aluminium caps

Figures, data and facts

KRONES Capping technology

Method of operation

After they have been sorted according to their positions in the sorter, the caps are fed to the capper via an open chute. A towing shoe positions the closures, which are then directly picked up by the bottle. If a closure is missing, a safety plunger prevents contact between the rollers and the bottle neck finish. Depending on the closure type, a "fixed" or a deep-drawing plunger is used for press-on and shaping. The thread is rolled out via moveable arms, and if necessary, the safety strip is flanged. The lateral pressure can be easily readjusted with adjustment screws.

Application

Glass bottle capping with pilfer-proof and Stelcap closures

Output range

The aluminium roll-on capper can fit crowns on between 10,000 and 60,000 bottles per hour with aluminium roll-on caps.



Rolling on of caps onto bottles

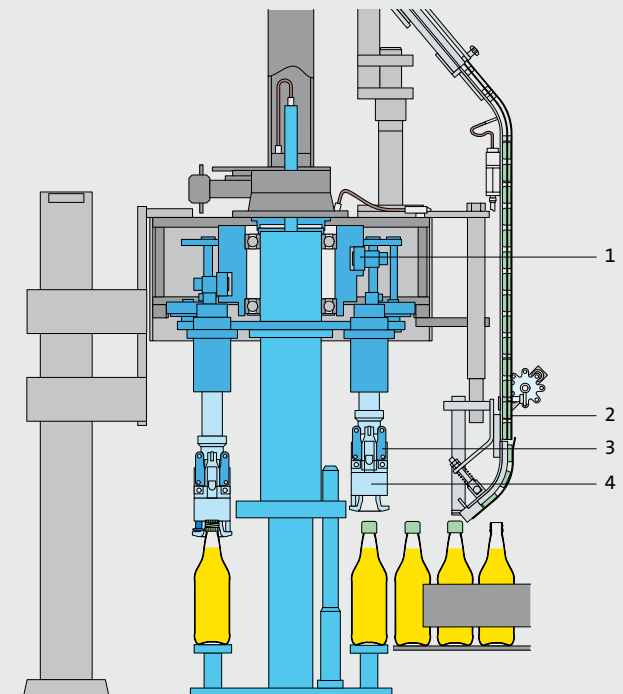

Cross-section of the roll-on capper structure

- 1 Cam roller
- 2 Thread rollers
- 3 Cap feed unit
- 4 Capping head

KRONES Roll-on unit for aluminium caps

Figures, data and facts

KRONES Capping technology

Design features

- Machine designed entirely with stainless steel
- Guide bushes made of plastic
- Capping head with ceramic ball bearings
- Adjustment of capping heads via adjustment screws
- Low-maintenance lifting elements and capping heads
- The entire capper can be flushed

Your benefits

- **Flexibility**
The thread and seaming roller arms can be quickly adjusted to the plunger dimension.
- **Can be optimally cleaned**
The capping heads can be cleaned perfectly with hot water or foam.
- **Retains its value**
The stainless steel design of the aluminium roll-on capper is highly resistant to cleaning agents and disinfectants.

Machine pitch	94	103	113	126	141	188	226	283
Pitch circle diameter (mm)								
360	12	11	10	9	8	6	5	4
540	18		15		12			
720	24	22	20	18	16	12		
1,080	36		30		24			



KRONES Natural cork capper

KRONES Capping technology

Traditional natural corks are the first choice as a closure for wine bottle, as they always have been. The KRONES natural cork capper works either with bottle neck evacuation, compression head heating or inert gas injection. Before closure, the corks are gently sorted and then fed into the compression head. The natural cork is not applied unless a bottle is ready. If the cork size changes, compression heads can be quickly and easily exchanged.



KRONES Natural cork capper

Figures, data and facts

KRONES Capping technology

Design features

- Bottle guiding parts made of wear-resistant plastic, infeed worm swivels out
- Lift cylinder force-actuated by cam track, can be removed quickly as a compact unit
- No lubrication required for compression heads
- Transparent cork reservoir allows for visual check of level
- Gentle cork handling with permanently positioned sorting cone and rotating container
- Vertical cork tube can be exchanged easily with plug-in connection
- Simple change-over to other bottle sizes

Additional equipment

- Electrical heating of compression heads for sterile working conditions
- Compression head is made of stainless steel
- Device for evacuation of the bottle neck before and during the capping process
- Inert gas injection before capping

Your benefits

- **Flexibility**
If the product changes, the capper can be quickly changed for other bottles and corks.
- **Economical**
Both bottles and corks are handled very gently in the machine.

Machine pitch	113	126	141	188	283
Pitch circle diameter (mm)					
360	10	9	8	6	4
540	15		12		
720	20	18	16		



KRONES Capping technology

Contact

Visit by a customer consultant

Further information material

Mr

Ms

First name

Surname

Company

Street, house number

Post Code

Town

Country

Telephone

Email

Contact person at KRONES (if known)

[▶ Send by email](#)



LCS Lifecycle Service

Each company, each facility, is unique. By making the appropriate selection from the capabilities offered by LCS Services and LCS Parts + Software, you will receive a package tailored precisely to your actual needs. And in addition, you benefit from our comprehensive expertise gained from operating production lines in the food and beverage industries, and in the cosmetic, chemical and pharmaceutical sectors as well.

[▶ more ...](#)

KRONES AG
Böhmerwaldstraße 5
93073 Neutraubling
Germany

Telephone: +49 9401 70-0
Telefax: +49 9401 70-2488
E-mail: info@krones.com
Internet: www.krones.com



TCO Total Cost of Ownership

The client is the paramount focus of KRONES' product strategy. This is why many of our new ideas emerge from close liaison between our service and sales people and the client on site. The R&D departments at KRONES then develop the appropriate products, geared without exception to cutting our clients' operating and raw-material costs (total cost of ownership).

[▶ more ...](#)



enviro

KRONES stands for innovative machines and high-performance lines. enviro epitomises its commitment to saving costs, by reducing energy consumption and ensuring economical use of natural resources. Intelligent machinery design to a maximised level of technical excellence enables us to grant exceptionally long lifetimes and economical efficiency to optimised ergonomics and safety for the operators and the maintenance staff alike.

[▶ more ...](#)

 **KRONES**